

# Simple Stresses in Machine Parts

1. Introduction.
2. Load.
3. Stress.
4. Strain.
5. Tensile Stress and Strain.
6. Compressive Stress and Strain.
7. Young's Modulus or Modulus of Elasticity.
8. Shear Stress and Strain
9. Shear Modulus or Modulus of Rigidity.
10. Bearing Stress.
11. Stress-Strain Diagram.
12. Working Stress.
13. Factor of Safety.
14. Selection of Factor of Safety.
15. Stresses in Composite Bars.
16. Stresses due to Change in Temperature—Thermal Stresses.
17. Linear and Lateral Strain.
18. Poisson's Ratio.
19. Volumetric Strain.
20. Bulk Modulus.
21. Relation between Bulk Modulus and Young's Modulus.
22. Relation between Young's Modulus and Modulus of Rigidity.
23. Impact Stress.
24. Resilience.



## 4.1 Introduction

In engineering practice, the machine parts are subjected to various forces which may be due to either one or more of the following:

1. Energy transmitted,
2. Weight of machine,
3. Frictional resistances,
4. Inertia of reciprocating parts,
5. Change of temperature, and
6. Lack of balance of moving parts.

The different forces acting on a machine part produces various types of stresses, which will be discussed in this chapter.

## 4.2 Load

It is defined as **any external force acting upon a machine part**. The following four types of the load are important from the subject point of view:

**1. Dead or steady load.** A load is said to be a dead or steady load, when it does not change in magnitude or direction.

**2. Live or variable load.** A load is said to be a live or variable load, when it changes continually.

**3. Suddenly applied or shock loads.** A load is said to be a suddenly applied or shock load, when it is suddenly applied or removed.

**4. Impact load.** A load is said to be an impact load, when it is applied with some initial velocity.

**Note:** A machine part resists a dead load more easily than a live load and a live load more easily than a shock load.

### 4.3 Stress

When some external system of forces or loads act on a body, the internal forces (equal and opposite) are set up at various sections of the body, which resist the external forces. This internal force per unit area at any section of the body is known as **unit stress** or simply a **stress**. It is denoted by a Greek letter sigma ( $\sigma$ ). Mathematically,

$$\text{Stress, } \sigma = P/A$$

where

$P$  = Force or load acting on a body, and

$A$  = Cross-sectional area of the body.

In S.I. units, the stress is usually expressed in Pascal (Pa) such that  $1 \text{ Pa} = 1 \text{ N/m}^2$ . In actual practice, we use bigger units of stress *i.e.* megapascal (MPa) and gigapascal (GPa), such that

$$1 \text{ MPa} = 1 \times 10^6 \text{ N/m}^2 = 1 \text{ N/mm}^2$$

and

$$1 \text{ GPa} = 1 \times 10^9 \text{ N/m}^2 = 1 \text{ kN/mm}^2$$

### 4.4 Strain

When a system of forces or loads act on a body, it undergoes some deformation. This deformation per unit length is known as **unit strain** or simply a **strain**. It is denoted by a Greek letter epsilon ( $\epsilon$ ). Mathematically,

$$\text{Strain, } \epsilon = \delta l / l \quad \text{or} \quad \delta l = \epsilon.l$$

where

$\delta l$  = Change in length of the body, and

$l$  = Original length of the body.

### 4.5 Tensile Stress and Strain

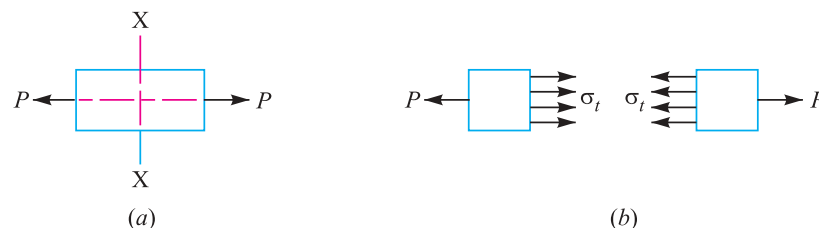

**Fig. 4.1.** Tensile stress and strain.

When a body is subjected to two equal and opposite axial pulls  $P$  (also called tensile load) as shown in Fig. 4.1 (a), then the stress induced at any section of the body is known as **tensile stress** as shown in Fig. 4.1 (b). A little consideration will show that due to the tensile load, there will be a decrease in cross-sectional area and an increase in length of the body. The ratio of the increase in length to the original length is known as **tensile strain**.

Let  $P$  = Axial tensile force acting on the body,  
 $A$  = Cross-sectional area of the body,  
 $l$  = Original length, and  
 $\delta l$  = Increase in length.

$\therefore$  Tensile stress,  $\sigma_t = P/A$   
 and tensile strain,  $\epsilon_t = \delta l / l$

### 4.6 Compressive Stress and Strain

When a body is subjected to two equal and opposite axial pushes  $P$  (also called compressive load) as shown in Fig. 4.2 (a), then the stress induced at any section of the body is known as **compressive stress** as shown in Fig. 4.2 (b). A little consideration will show that due to the compressive load, there will be an increase in cross-sectional area and a decrease in length of the body. The ratio of the decrease in length to the original length is known as **compressive strain**.



Shock absorber of a motorcycle absorbs stresses.

Note : This picture is given as additional information and is not a direct example of the current chapter.

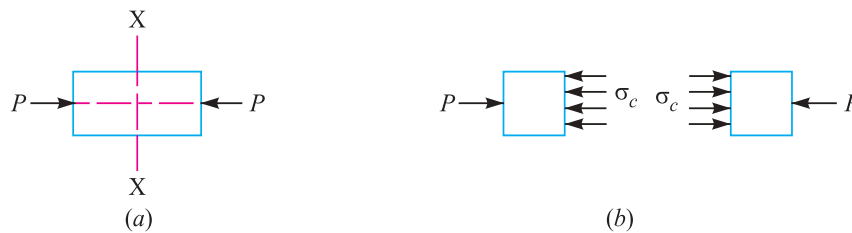

Fig. 4.2. Compressive stress and strain.

Let  $P$  = Axial compressive force acting on the body,  
 $A$  = Cross-sectional area of the body,  
 $l$  = Original length, and  
 $\delta l$  = Decrease in length.

$\therefore$  Compressive stress,  $\sigma_c = P/A$   
 and compressive strain,  $\epsilon_c = \delta l / l$

Note : In case of tension or compression, the area involved is at right angles to the external force applied.

### 4.7 Young's Modulus or Modulus of Elasticity

**Hooke's law\*** states that when a material is loaded within elastic limit, the stress is directly proportional to strain, *i.e.*

$$\sigma \propto \epsilon \quad \text{or} \quad \sigma = E.\epsilon$$

$$\therefore E = \frac{\sigma}{\epsilon} = \frac{P \times l}{A \times \delta l}$$

\* It is named after Robert Hooke, who first established it by experiments in 1678.

where  $E$  is a constant of proportionality known as *Young's modulus* or *modulus of elasticity*. In S.I. units, it is usually expressed in GPa *i.e.* GN/m<sup>2</sup> or kN/mm<sup>2</sup>. It may be noted that Hooke's law holds good for tension as well as compression.

The following table shows the values of modulus of elasticity or Young's modulus ( $E$ ) for the materials commonly used in engineering practice.

**Table 4.1. Values of E for the commonly used engineering materials.**

| Material         | Modulus of elasticity ( $E$ ) in GPa <i>i.e.</i> GN/m <sup>2</sup> or kN/mm <sup>2</sup> |
|------------------|--|
| Steel and Nickel | 200 to 220   |
| Wrought iron     | 190 to 200   |
| Cast iron        | 100 to 160   |
| Copper           | 90 to 110  |
| Brass            | 80 to 90   |
| Aluminium        | 60 to 80   |
| Timber           | 10   |

**Example 4.1.** A coil chain of a crane required to carry a maximum load of 50 kN, is shown in Fig. 4.3.

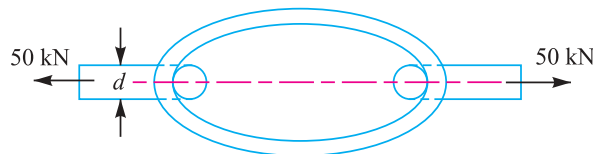

**Fig. 4.3**

Find the diameter of the link stock, if the permissible tensile stress in the link material is not to exceed 75 MPa.

**Solution.** Given :  $P = 50 \text{ kN} = 50 \times 10^3 \text{ N}$  ;  $\sigma_t = 75 \text{ MPa} = 75 \text{ N/mm}^2$

Let  $d =$  Diameter of the link stock in mm.

$$\therefore \text{Area, } A = \frac{\pi}{4} \times d^2 = 0.7854 d^2$$

We know that the maximum load ( $P$ ),

$$50 \times 10^3 = \sigma_t \cdot A = 75 \times 0.7854 d^2 = 58.9 d^2$$

$$\therefore d^2 = 50 \times 10^3 / 58.9 = 850 \text{ or } d = 29.13 \text{ say } 30 \text{ mm Ans.}$$

**Example 4.2.** A cast iron link, as shown in Fig. 4.4, is required to transmit a steady tensile load of 45 kN. Find the tensile stress induced in the link material at sections A-A and B-B.

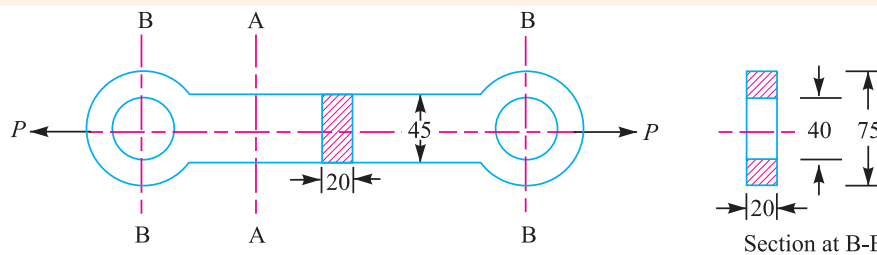

**Fig. 4.4.** All dimensions in mm.

**Solution.** Given :  $P = 45 \text{ kN} = 45 \times 10^3 \text{ N}$

**Tensile stress induced at section A-A**

We know that the cross-sectional area of link at section A-A,

$$A_1 = 45 \times 20 = 900 \text{ mm}^2$$

∴ Tensile stress induced at section A-A,

$$\sigma_{t1} = \frac{P}{A_1} = \frac{45 \times 10^3}{900} = 50 \text{ N/mm}^2 = 50 \text{ MPa Ans.}$$

**Tensile stress induced at section B-B**

We know that the cross-sectional area of link at section B-B,

$$A_2 = 20 (75 - 40) = 700 \text{ mm}^2$$

∴ Tensile stress induced at section B-B,

$$\sigma_{t2} = \frac{P}{A_2} = \frac{45 \times 10^3}{700} = 64.3 \text{ N/mm}^2 = 64.3 \text{ MPa Ans.}$$

**Example 4.3.** A hydraulic press exerts a total load of 3.5 MN. This load is carried by two steel rods, supporting the upper head of the press. If the safe stress is 85 MPa and  $E = 210 \text{ kN/mm}^2$ , find : 1. diameter of the rods, and 2. extension in each rod in a length of 2.5 m.

**Solution.** Given :  $P = 3.5 \text{ MN} = 3.5 \times 10^6 \text{ N}$  ;  $\sigma_t = 85 \text{ MPa} = 85 \text{ N/mm}^2$  ;  $E = 210 \text{ kN/mm}^2 = 210 \times 10^3 \text{ N/mm}^2$  ;  $l = 2.5 \text{ m} = 2.5 \times 10^3 \text{ mm}$

**1. Diameter of the rods**

Let  $d =$  Diameter of the rods in mm.

$$\therefore \text{Area, } A = \frac{\pi}{4} \times d^2 = 0.7854 d^2$$

Since the load  $P$  is carried by two rods, therefore load carried by each rod,

$$P_1 = \frac{P}{2} = \frac{3.5 \times 10^6}{2} = 1.75 \times 10^6 \text{ N}$$

We know that load carried by each rod ( $P_1$ ),

$$1.75 \times 10^6 = \sigma_t \cdot A = 85 \times 0.7854 d^2 = 66.76 d^2$$

$$\therefore d^2 = 1.75 \times 10^6 / 66.76 = 26213 \text{ or } d = 162 \text{ mm Ans.}$$

**2. Extension in each rod**

Let  $\delta l =$  Extension in each rod.

We know that Young's modulus ( $E$ ),

$$210 \times 10^3 = \frac{P_1 \times l}{A \times \delta l} = \frac{\sigma_t \times l}{\delta l} = \frac{85 \times 2.5 \times 10^3}{\delta l} = \frac{212.5 \times 10^3}{\delta l} \dots \left( \because \frac{P_1}{A} = \sigma_t \right)$$

$$\therefore \delta l = 212.5 \times 10^3 / (210 \times 10^3) = 1.012 \text{ mm Ans.}$$

**Example 4.4.** A rectangular base plate is fixed at each of its four corners by a 20 mm diameter bolt and nut as shown in Fig. 4.5. The plate rests on washers of 22 mm internal diameter and 50 mm external diameter. Copper washers which are placed between the nut and the plate are of 22 mm internal diameter and 44 mm external diameter.

If the base plate carries a load of 120 kN (including self-weight, which is equally distributed on the four corners), calculate the stress on the lower washers before the nuts are tightened.

What could be the stress in the upper and lower washers, when the nuts are tightened so as to produce a tension of 5 kN on each bolt?

**Solution.** Given :  $d = 20$  mm ;  $d_1 = 22$  mm ;  $d_2 = 50$  mm ;  $d_3 = 22$  mm ;  $d_4 = 44$  mm ;  $P_1 = 120$  kN ;  $P_2 = 5$  kN

**Stress on the lower washers before the nuts are tightened**

We know that area of lower washers,

$$A_1 = \frac{\pi}{4} [(d_2)^2 - (d_1)^2] = \frac{\pi}{4} [(50)^2 - (22)^2] = 1583 \text{ mm}^2$$

and area of upper washers,

$$A_2 = \frac{\pi}{4} [(d_4)^2 - (d_3)^2] = \frac{\pi}{4} [(44)^2 - (22)^2] = 1140 \text{ mm}^2$$

Since the load of 120 kN on the four washers is equally distributed, therefore load on each lower washer before the nuts are tightened,

$$P_1 = \frac{120}{4} = 30 \text{ kN} = 30\,000 \text{ N}$$

We know that stress on the lower washers before the nuts are tightened,

$$\sigma_{c1} = \frac{P_1}{A_1} = \frac{30\,000}{1583} = 18.95 \text{ N/mm}^2 = 18.95 \text{ MPa} \quad \text{Ans.}$$

**Stress on the upper washers when the nuts are tightened**

Tension on each bolt when the nut is tightened,

$$P_2 = 5 \text{ kN} = 5000 \text{ N}$$

∴ Stress on the upper washers when the nut is tightened,

$$\sigma_{c2} = \frac{P_2}{A_2} = \frac{5000}{1140} = 4.38 \text{ N/mm}^2 = 4.38 \text{ MPa} \quad \text{Ans.}$$

**Stress on the lower washers when the nuts are tightened**

We know that the stress on the lower washers when the nuts are tightened,

$$\sigma_{c3} = \frac{P_1 + P_2}{A_1} = \frac{30\,000 + 5000}{1583} = 22.11 \text{ N/mm}^2 = 22.11 \text{ MPa} \quad \text{Ans.}$$

**Example 4.5.** The piston rod of a steam engine is 50 mm in diameter and 600 mm long. The diameter of the piston is 400 mm and the maximum steam pressure is 0.9 N/mm<sup>2</sup>. Find the compression of the piston rod if the Young's modulus for the material of the piston rod is 210 kN/mm<sup>2</sup>.

**Solution.** Given :  $d = 50$  mm ;  $l = 600$  mm ;  $D = 400$  mm ;  $p = 0.9$  N/mm<sup>2</sup> ;  $E = 210$  kN/mm<sup>2</sup> =  $210 \times 10^3$  N/mm<sup>2</sup>

Let  $\delta l$  = Compression of the piston rod.

We know that cross-sectional area of piston,

$$= \frac{\pi}{4} \times D^2 = \frac{\pi}{4} (400)^2 = 125\,680 \text{ mm}^2$$

∴ Maximum load acting on the piston due to steam,

$$\begin{aligned} P &= \text{Cross-sectional area of piston} \times \text{Steam pressure} \\ &= 125\,680 \times 0.9 = 113\,110 \text{ N} \end{aligned}$$

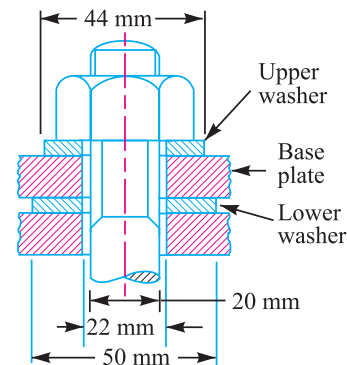

Fig. 4.5

We also know that cross-sectional area of piston rod,

$$A = \frac{\pi}{4} \times d^2 = \frac{\pi}{4} (50)^2 = 1964 \text{ mm}^2$$

and Young's modulus ( $E$ ),

$$210 \times 10^3 = \frac{P \times l}{A \times \delta l} = \frac{113\,110 \times 600}{1964 \times \delta l} = \frac{34\,555}{\delta l}$$

$$\therefore \delta l = 34\,555 / (210 \times 10^3) = 0.165 \text{ mm Ans.}$$



This picture shows a jet engine being tested for bearing high stresses.

### 4.8 Shear Stress and Strain

When a body is subjected to two equal and opposite forces acting tangentially across the resisting section, as a result of which the body tends to shear off the section, then the stress induced is called **shear stress**.

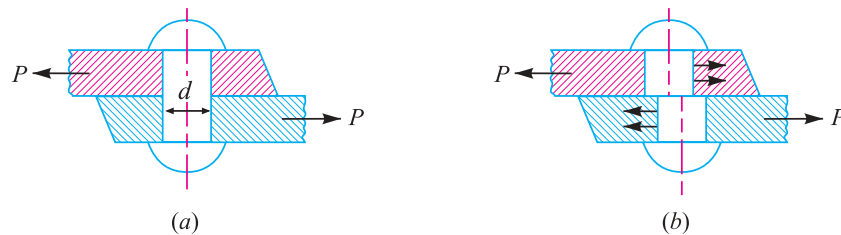

Fig. 4.6. Single shearing of a riveted joint.

The corresponding strain is known as **shear strain** and it is measured by the angular deformation accompanying the shear stress. The shear stress and shear strain are denoted by the Greek letters tau ( $\tau$ ) and phi ( $\phi$ ) respectively. Mathematically,

$$\text{Shear stress, } \tau = \frac{\text{Tangential force}}{\text{Resisting area}}$$

Consider a body consisting of two plates connected by a rivet as shown in Fig. 4.6 (a). In this case, the tangential force  $P$  tends to shear off the rivet at one cross-section as shown in Fig. 4.6 (b). It may be noted that when the tangential force is resisted by one cross-section of the rivet (or when shearing takes place at one cross-section of the rivet), then the rivets are said to be in **single shear**. In such a case, the area resisting the shear off the rivet,

$$A = \frac{\pi}{4} \times d^2$$

and shear stress on the rivet cross-section,

$$\tau = \frac{P}{A} = \frac{P}{\frac{\pi}{4} \times d^2} = \frac{4P}{\pi d^2}$$

Now let us consider two plates connected by the two cover plates as shown in Fig. 4.7 (a). In this case, the tangential force  $P$  tends to shear off the rivet at two cross-sections as shown in Fig. 4.7 (b). It may be noted that when the tangential force is resisted by two cross-sections of the rivet (or

when the shearing takes place at two cross-sections of the rivet), then the rivets are said to be in **double shear**. In such a case, the area resisting the shear off the rivet,

$$A = 2 \times \frac{\pi}{4} \times d^2 \quad \dots \text{(For double shear)}$$

and shear stress on the rivet cross-section,

$$\tau = \frac{P}{A} = \frac{P}{2 \times \frac{\pi}{4} \times d^2} = \frac{2P}{\pi d^2}$$

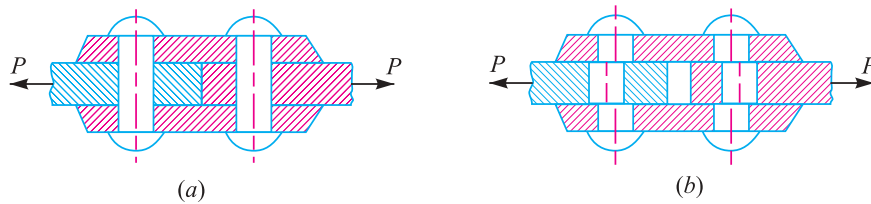

**Fig. 4.7.** Double shearing of a riveted joint.

**Notes :** 1. All lap joints and single cover butt joints are in single shear, while the butt joints with double cover plates are in double shear.

2. In case of shear, the area involved is parallel to the external force applied.

3. When the holes are to be punched or drilled in the metal plates, then the tools used to perform the operations must overcome the ultimate shearing resistance of the material to be cut. If a hole of diameter ‘d’ is to be punched in a metal plate of thickness ‘t’, then the area to be sheared,

$$A = \pi d \times t$$

and the maximum shear resistance of the tool or the force required to punch a hole,

$$P = A \times \tau_u = \pi d \times t \times \tau_u$$

where

$\tau_u$  = Ultimate shear strength of the material of the plate.

### 4.9 Shear Modulus or Modulus of Rigidity

It has been found experimentally that within the elastic limit, the shear stress is directly proportional to shear strain. Mathematically

$$\tau \propto \phi \quad \text{or} \quad \tau = C \cdot \phi \quad \text{or} \quad \tau / \phi = C$$

where

$\tau$  = Shear stress,

$\phi$  = Shear strain, and

C = Constant of proportionality, known as shear modulus or modulus of rigidity. It is also denoted by N or G.

The following table shows the values of modulus of rigidity (C) for the materials in every day use:

**Table 4.2. Values of C for the commonly used materials.**

| Material     | Modulus of rigidity (C) in GPa i.e. GN/m <sup>2</sup> or kN/mm <sup>2</sup> |
|--------------|---|
| Steel        | 80 to 100   |
| Wrought iron | 80 to 90  |
| Cast iron    | 40 to 50  |
| Copper       | 30 to 50  |
| Brass        | 30 to 50  |
| Timber       | 10  |



**Example 4.6.** Calculate the force required to punch a circular blank of 60 mm diameter in a plate of 5 mm thick. The ultimate shear stress of the plate is 350 N/mm<sup>2</sup>.

**Solution.** Given:  $d = 60 \text{ mm}$  ;  $t = 5 \text{ mm}$  ;  $\tau_u = 350 \text{ N/mm}^2$

We know that area under shear,

$$A = \pi d \times t = \pi \times 60 \times 5 = 942.6 \text{ mm}^2$$

and force required to punch a hole,

$$P = A \times \tau_u = 942.6 \times 350 = 329\,910 \text{ N} = 329.91 \text{ kN} \quad \text{Ans.}$$

**Example 4.7.** A pull of 80 kN is transmitted from a bar X to the bar Y through a pin as shown in Fig. 4.8.

If the maximum permissible tensile stress in the bars is 100 N/mm<sup>2</sup> and the permissible shear stress in the pin is 80 N/mm<sup>2</sup>, find the diameter of bars and of the pin.

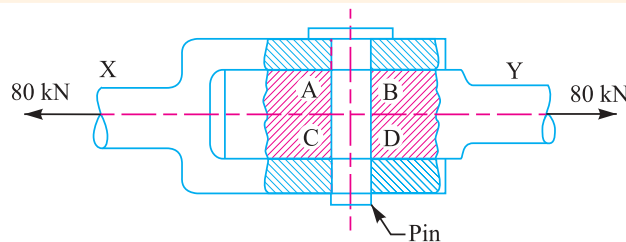

Fig. 4.8

**Solution.** Given :  $P = 80 \text{ kN} = 80 \times 10^3 \text{ N}$ ;  
 $\sigma_t = 100 \text{ N/mm}^2$  ;  $\tau = 80 \text{ N/mm}^2$

**Diameter of the bars**

Let  $D_b =$  Diameter of the bars in mm.

$$\therefore \text{Area, } A_b = \frac{\pi}{4} (D_b)^2 = 0.7854 (D_b)^2$$

We know that permissible tensile stress in the bar ( $\sigma_t$ ),

$$100 = \frac{P}{A_b} = \frac{80 \times 10^3}{0.7854 (D_b)^2} = \frac{101\,846}{(D_b)^2}$$

$$\therefore (D_b)^2 = 101\,846 / 100 = 1018.46$$

or  $D_b = 32 \text{ mm} \quad \text{Ans.}$

**Diameter of the pin**

Let  $D_p =$  Diameter of the pin in mm.

Since the tensile load  $P$  tends to shear off the pin at two sections *i.e.* at  $AB$  and  $CD$ , therefore the pin is in double shear.

$\therefore$  Resisting area,

$$A_p = 2 \times \frac{\pi}{4} (D_p)^2 = 1.571 (D_p)^2$$

We know that permissible shear stress in the pin ( $\tau$ ),

$$80 = \frac{P}{A_p} = \frac{80 \times 10^3}{1.571 (D_p)^2} = \frac{50.9 \times 10^3}{(D_p)^2}$$

$\therefore (D_p)^2 = 50.9 \times 10^3 / 80 = 636.5$  or  $D_p = 25.2 \text{ mm} \quad \text{Ans.}$



High force injection moulding machine.

Note : This picture is given as additional information and is not a direct example of the current chapter.

### 4.10 Bearing Stress

A localised compressive stress at the surface of contact between two members of a machine part, that are relatively at rest is known as **bearing stress** or **crushing stress**. The bearing stress is taken into account in the design of riveted joints, cotter joints, knuckle joints, etc. Let us consider a riveted joint subjected to a load  $P$  as shown in Fig. 4.9. In such a case, the bearing stress or crushing stress (stress at the surface of contact between the rivet and a plate),

$$\sigma_b \text{ (or } \sigma_c) = \frac{P}{d.t.n}$$

where

$d$  = Diameter of the rivet,

$t$  = Thickness of the plate,

$d.t$  = Projected area of the rivet, and

$n$  = Number of rivets per pitch length in bearing or crushing.

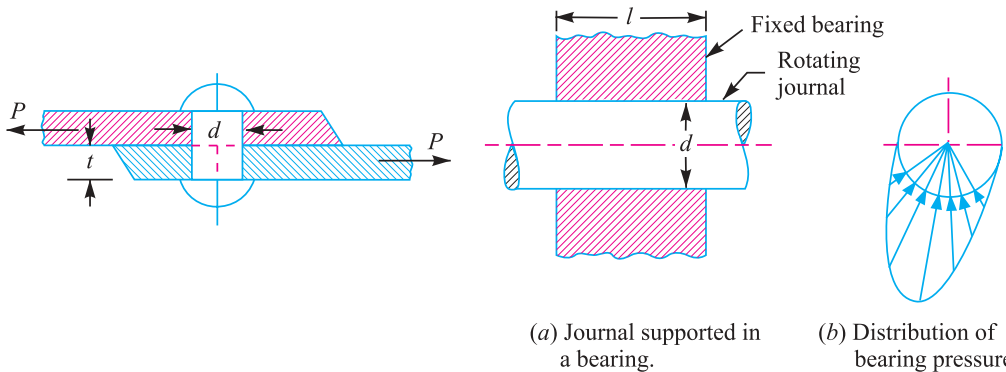

**Fig. 4.9.** Bearing stress in a riveted joint. **Fig. 4.10.** Bearing pressure in a journal supported in a bearing.

It may be noted that the local compression which exists at the surface of contact between two members of a machine part that are in relative motion, is called **bearing pressure** (not the bearing stress). This term is commonly used in the design of a journal supported in a bearing, pins for levers, crank pins, clutch lining, etc. Let us consider a journal rotating in a fixed bearing as shown in Fig. 4.10 (a). The journal exerts a bearing pressure on the curved surfaces of the brasses immediately below it. The distribution of this bearing pressure will not be uniform, but it will be in accordance with the shape of the surfaces in contact and deformation characteristics of the two materials. The distribution of bearing pressure will be similar to that as shown in Fig. 4.10 (b). Since the actual bearing pressure is difficult to determine, therefore the average bearing pressure is usually calculated by dividing the load to the projected area of the curved surfaces in contact. Thus, the average bearing pressure for a journal supported in a bearing is given by

$$p_b = \frac{P}{l.d}$$

where

$p_b$  = Average bearing pressure,

$P$  = Radial load on the journal,

$l$  = Length of the journal in contact, and

$d$  = Diameter of the journal.

**Example 4.8.** Two plates 16 mm thick are joined by a double riveted lap joint as shown in Fig. 4.11. The rivets are 25 mm in diameter.

Find the crushing stress induced between the plates and the rivet, if the maximum tensile load on the joint is 48 kN.

**Solution.** Given :  $t = 16 \text{ mm}$  ;  $d = 25 \text{ mm}$  ;  
 $P = 48 \text{ kN} = 48 \times 10^3 \text{ N}$

Since the joint is double riveted, therefore, strength of two rivets in bearing (or crushing) is taken. We know that crushing stress induced between the plates and the rivets,

$$\sigma_c = \frac{P}{d \cdot t \cdot n} = \frac{48 \times 10^3}{25 \times 16 \times 2} = 60 \text{ N/mm}^2 \text{ Ans.}$$

**Example 4.9.** A journal 25 mm in diameter supported in sliding bearings has a maximum end reaction of 2500 N. Assuming an allowable bearing pressure of 5 N/mm<sup>2</sup>, find the length of the sliding bearing.

**Solution.** Given :  $d = 25 \text{ mm}$  ;  $P = 2500 \text{ N}$  ;  $p_b = 5 \text{ N/mm}^2$

Let  $l =$  Length of the sliding bearing in mm.

We know that the projected area of the bearing,

$$A = l \times d = l \times 25 = 25 l \text{ mm}^2$$

∴ Bearing pressure ( $p_b$ ),

$$5 = \frac{P}{A} = \frac{2500}{25 l} = \frac{100}{l} \quad \text{or} \quad l = \frac{100}{5} = 20 \text{ mm Ans.}$$

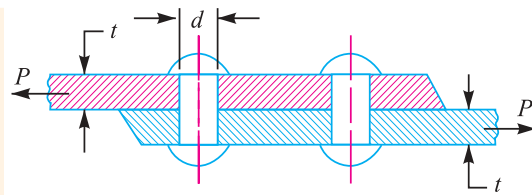

Fig. 4.11

### 4.11 Stress-strain Diagram

In designing various parts of a machine, it is necessary to know how the material will function in service. For this, certain characteristics or properties of the material should be known. The mechanical properties mostly used in mechanical engineering practice are commonly determined from a standard tensile test. This test consists of gradually loading a standard specimen of a material and noting the corresponding values of load and elongation until the specimen fractures. The load is applied and measured by a testing machine. The stress is determined by dividing the load values by the original cross-sectional area of the specimen. The elongation is measured by determining the amounts that two reference points on the specimen are moved apart by the action of the machine. The original distance between the two reference points is known as **gauge length**. The strain is determined by dividing the elongation values by the gauge length.

The values of the stress and corresponding strain are used to draw the stress-strain diagram of the material tested. A stress-strain diagram for a mild steel under tensile test is shown in Fig. 4.12 (a). The various properties of the material are discussed below :



In addition to bearing the stresses, some machine parts are made of stainless steel to make them corrosion resistant.

**Note :** This picture is given as additional information and is not a direct example of the current chapter.

**1. Proportional limit.** We see from the diagram that from point  $O$  to  $A$  is a straight line, which represents that the stress is proportional to strain. Beyond point  $A$ , the curve slightly deviates from the straight line. It is thus obvious, that Hooke's law holds good up to point  $A$  and it is known as **proportional limit**. It is defined as that stress at which the stress-strain curve begins to deviate from the straight line.

**2. Elastic limit.** It may be noted that even if the load is increased beyond point  $A$  upto the point  $B$ , the material will regain its shape and size when the load is removed. This means that the material has elastic properties up to the point  $B$ . This point is known as **elastic limit**. It is defined as the stress developed in the material without any permanent set.

**Note:** Since the above two limits are very close to each other, therefore, for all practical purposes these are taken to be equal.

**3. Yield point.** If the material is stressed beyond point  $B$ , the plastic stage will reach *i.e.* on the removal of the load, the material will not be able to recover its original size and shape. A little consideration will show that beyond point  $B$ , the strain increases at a faster rate with any increase in the stress until the point  $C$  is reached. At this point, the material yields before the load and there is an appreciable strain without any increase in stress. In case of mild steel, it will be seen that a small load drops to  $D$ , immediately after yielding commences. Hence there are two yield points  $C$  and  $D$ . The points  $C$  and  $D$  are called the **upper** and **lower yield points** respectively. The stress corresponding to yield point is known as **yield point stress**.

**4. Ultimate stress.** At  $D$ , the specimen regains some strength and higher values of stresses are required for higher strains, than those between  $A$  and  $D$ . The stress (or load) goes on increasing till the

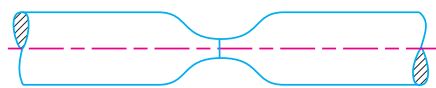
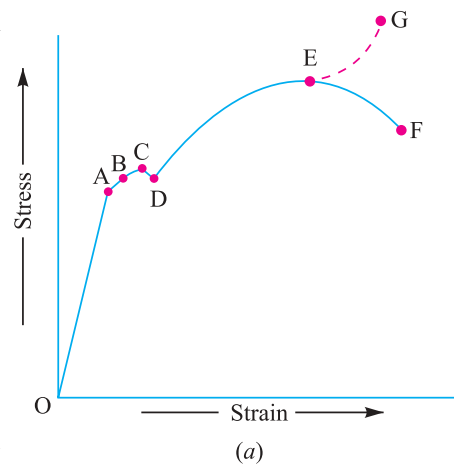

(b) Shape of specimen after elongation.

**Fig. 4.12.** Stress-strain diagram for a mild steel.



A crane used on a ship.

**Note :** This picture is given as additional information and is not a direct example of the current chapter.

point *E* is reached. The gradual increase in the strain (or length) of the specimen is followed with the uniform reduction of its cross-sectional area. The work done, during stretching the specimen, is transformed largely into heat and the specimen becomes hot. At *E*, the stress, which attains its maximum value is known as **ultimate stress**. It is defined as the largest stress obtained by dividing the largest value of the load reached in a test to the original cross-sectional area of the test piece.

**5. Breaking stress.** After the specimen has reached the ultimate stress, a neck is formed, which decreases the cross-sectional area of the specimen, as shown in Fig. 4.12 (b). A little consideration will show that the stress (or load) necessary to break away the specimen, is less than the maximum stress. The stress is, therefore, reduced until the specimen breaks away at point *F*. The stress corresponding to point *F* is known as **breaking stress**.

**Note :** The breaking stress (*i.e.* stress at *F* which is less than at *E*) appears to be somewhat misleading. As the formation of a neck takes place at *E* which reduces the cross-sectional area, it causes the specimen suddenly to fail at *F*. If for each value of the strain between *E* and *F*, the tensile load is divided by the reduced cross-sectional area at the narrowest part of the neck, then the true stress-strain curve will follow the dotted line *EG*. However, it is an established practice, to calculate strains on the basis of original cross-sectional area of the specimen.

**6. Percentage reduction in area.** It is the difference between the original cross-sectional area and cross-sectional area at the neck (*i.e.* where the fracture takes place). This difference is expressed as percentage of the original cross-sectional area.

Let  $A =$  Original cross-sectional area, and  
 $a =$  Cross-sectional area at the neck.

Then reduction in area  $= A - a$

and percentage reduction in area  $= \frac{A - a}{A} \times 100$

**7. Percentage elongation.** It is the percentage increase in the standard gauge length (*i.e.* original length) obtained by measuring the fractured specimen after bringing the broken parts together.

Let  $l =$  Gauge length or original length, and  
 $L =$  Length of specimen after fracture or final length.

$\therefore$  Elongation  $= L - l$

and percentage elongation  $= \frac{L - l}{l} \times 100$

**Note :** The percentage elongation gives a measure of ductility of the metal under test. The amount of local extensions depends upon the material and also on the transverse dimensions of the test piece. Since the specimens are to be made from bars, strips, sheets, wires, forgings, castings, etc., therefore it is not possible to make all specimens of one standard size. Since the dimensions of the specimen influence the result, therefore some standard means of comparison of results are necessary.



A recovery truck with crane.

**Note :** This picture is given as additional information and is not a direct example of the current chapter.

## 100 ■ A Textbook of Machine Design

As a result of series of experiments, Barba established a law that in tension, similar test pieces deform similarly and two test pieces are said to be similar if they have the same value of  $\frac{l}{\sqrt{A}}$ , where  $l$  is the gauge length and  $A$  is the cross-sectional area. A little consideration will show that the same material will give the same percentage elongation and percentage reduction in area.

It has been found experimentally by Unwin that the general extension (up to the maximum load) is proportional to the gauge length of the test piece and that the local extension (from maximum load to the breaking load) is proportional to the square root of the cross-sectional area. According to Unwin's formula, the increase in length,

$$\delta l = b.l + C\sqrt{A}$$

and percentage elongation  $= \frac{\delta l}{l} \times 100$

where

$$l = \text{Gauge length,}$$

$$A = \text{Cross-sectional area, and}$$

$$b \text{ and } C = \text{Constants depending upon the quality of the material.}$$

The values of  $b$  and  $C$  are determined by finding the values of  $\delta l$  for two test pieces of known length ( $l$ ) and area ( $A$ ).

**Example 4.10.** A mild steel rod of 12 mm diameter was tested for tensile strength with the gauge length of 60 mm. Following observations were recorded :

Final length = 80 mm; Final diameter = 7 mm; Yield load = 3.4 kN and Ultimate load = 6.1 kN.

Calculate : 1. yield stress, 2. ultimate tensile stress, 3. percentage reduction in area, and 4. percentage elongation.

**Solution.** Given :  $D = 12$  mm ;  $l = 60$  mm ;  $L = 80$  mm ;  $d = 7$  mm ;  $W_y = 3.4$  kN = 3400 N;  $W_u = 6.1$  kN = 6100 N

We know that original area of the rod,

$$A = \frac{\pi}{4} \times D^2 = \frac{\pi}{4} (12)^2 = 113 \text{ mm}^2$$

and final area of the rod,

$$a = \frac{\pi}{4} \times d^2 = \frac{\pi}{4} (7)^2 = 38.5 \text{ mm}^2$$

### 1. Yield stress

We know that yield stress

$$= \frac{W_y}{A} = \frac{3400}{113} = 30.1 \text{ N/mm}^2 = 30.1 \text{ MPa} \quad \text{Ans.}$$

### 2. Ultimate tensile stress

We know the ultimate tensile stress

$$= \frac{W_u}{A} = \frac{6100}{113} = 54 \text{ N/mm}^2 = 54 \text{ MPa} \quad \text{Ans.}$$

### 3. Percentage reduction in area

We know that percentage reduction in area

$$= \frac{A - a}{A} = \frac{113 - 38.5}{113} = 0.66 \text{ or } 66\% \quad \text{Ans.}$$

#### 4. Percentage elongation

We know that percentage elongation

$$= \frac{L - l}{L} = \frac{80 - 60}{80} = 0.25 \text{ or } 25\% \text{ Ans.}$$

#### 4.12 Working Stress

When designing machine parts, it is desirable to keep the stress lower than the maximum or ultimate stress at which failure of the material takes place. This stress is known as the **working stress** or **design stress**. It is also known as **safe** or **allowable stress**.

**Note :** By failure it is not meant actual breaking of the material. Some machine parts are said to fail when they have plastic deformation set in them, and they no more perform their function satisfactory.

#### 4.13 Factor of Safety

It is defined, in general, as the **ratio of the maximum stress to the working stress**. Mathematically,

$$\text{Factor of safety} = \frac{\text{Maximum stress}}{\text{Working or design stress}}$$

In case of ductile materials *e.g.* mild steel, where the yield point is clearly defined, the factor of safety is based upon the yield point stress. In such cases,

$$\text{Factor of safety} = \frac{\text{Yield point stress}}{\text{Working or design stress}}$$

In case of brittle materials *e.g.* cast iron, the yield point is not well defined as for ductile materials. Therefore, the factor of safety for brittle materials is based on ultimate stress.

$$\therefore \text{Factor of safety} = \frac{\text{Ultimate stress}}{\text{Working or design stress}}$$

This relation may also be used for ductile materials.

**Note:** The above relations for factor of safety are for static loading.

#### 4.14 Selection of Factor of Safety

The selection of a proper factor of safety to be used in designing any machine component depends upon a number of considerations, such as the material, mode of manufacture, type of stress, general service conditions and shape of the parts. Before selecting a proper factor of safety, a design engineer should consider the following points :

1. The reliability of the properties of the material and change of these properties during service ;
2. The reliability of test results and accuracy of application of these results to actual machine parts ;
3. The reliability of applied load ;
4. The certainty as to exact mode of failure ;
5. The extent of simplifying assumptions ;
6. The extent of localised stresses ;
7. The extent of initial stresses set up during manufacture ;
8. The extent of loss of life if failure occurs ; and
9. The extent of loss of property if failure occurs.

Each of the above factors must be carefully considered and evaluated. The high factor of safety results in unnecessary risk of failure. The values of factor of safety based on ultimate strength for different materials and type of load are given in the following table:

Table 4.3. Values of factor of safety.

| Material                  | Steady load | Live load | Shock load |
|---------------------------|-------------|-----------|------------|
| Cast iron                 | 5 to 6      | 8 to 12   | 16 to 20   |
| Wrought iron              | 4           | 7         | 10 to 15   |
| Steel                     | 4           | 8         | 12 to 16   |
| Soft materials and alloys | 6           | 9         | 15         |
| Leather                   | 9           | 12        | 15         |
| Timber                    | 7           | 10 to 15  | 20         |

### 4.15 Stresses in Composite Bars

A composite bar may be defined as a bar made up of two or more different materials, joined together, in such a manner that the system extends or contracts as one unit, equally, when subjected to tension or compression. In case of composite bars, the following points should be kept in view:

1. The extension or contraction of the bar being equal, the strain *i.e.* deformation per unit length is also equal.
2. The total external load on the bar is equal to the sum of the loads carried by different materials.

Consider a composite bar made up of two different materials as shown in Fig. 4.13.

Let  $P_1$  = Load carried by bar 1,  
 $A_1$  = Cross-sectional area of bar 1,  
 $\sigma_1$  = Stress produced in bar 1,  
 $E_1$  = Young's modulus of bar 1,  
 $P_2, A_2, \sigma_2, E_2$  = Corresponding values of bar 2,  
 $P$  = Total load on the composite bar,  
 $l$  = Length of the composite bar, and  
 $\delta l$  = Elongation of the composite bar.

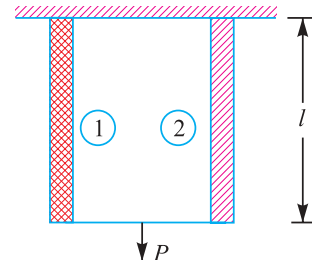

Fig. 4.13. Stresses in composite bars.

We know that  $P = P_1 + P_2$  ... (i)

Stress in bar 1,  $\sigma_1 = \frac{P_1}{A_1}$

and strain in bar 1,  $\epsilon = \frac{\sigma_1}{E_1} = \frac{P_1}{A_1 \cdot E_1}$

∴ Elongation of bar 1,

$$\delta l_1 = \frac{P_1 \cdot l}{A_1 \cdot E_1}$$

Similarly, elongation of bar 2,

$$\delta l_2 = \frac{P_2 \cdot l}{A_2 \cdot E_2}$$

Since  $\delta l_1 = \delta l_2$



A Material handling system

Note : This picture is given as additional information and is not a direct example of the current chapter.



Therefore,  $\frac{P_1 \cdot l}{A_1 \cdot E_1} = \frac{P_2 \cdot l}{A_2 \cdot E_2}$  or  $P_1 = P_2 \times \frac{A_1 \cdot E_1}{A_2 \cdot E_2}$  ...**(ii)**

But  $P = P_1 + P_2 = P_2 \times \frac{A_1 \cdot E_1}{A_2 \cdot E_2} + P_2 = P_2 \left( \frac{A_1 \cdot E_1}{A_2 \cdot E_2} + 1 \right)$   
 $= P_2 \left( \frac{A_1 \cdot E_1 + A_2 \cdot E_2}{A_2 \cdot E_2} \right)$

or  $P_2 = P \times \frac{A_2 \cdot E_2}{A_1 \cdot E_1 + A_2 \cdot E_2}$  ...**(iii)**

Similarly  $P_1 = P \times \frac{A_1 \cdot E_1}{A_1 \cdot E_1 + A_2 \cdot E_2}$  ...[From equation **(ii)**] ...**(iv)**

We know that

$$\frac{P_1 \cdot l}{A_1 \cdot E_1} = \frac{P_2 \cdot l}{A_2 \cdot E_2}$$

∴  $\frac{\sigma_1}{E_1} = \frac{\sigma_2}{E_2}$

or  $\sigma_1 = \frac{E_1}{E_2} \times \sigma_2$  ...**(v)**

Similarly,  $\sigma_2 = \frac{E_2}{E_1} \times \sigma_1$  ...**(vi)**

From the above equations, we can find out the stresses produced in the different bars. We also know that

$$P = P_1 + P_2 = \sigma_1 \cdot A_1 + \sigma_2 \cdot A_2$$

From this equation, we can also find out the stresses produced in different bars.

**Note :** The ratio  $E_1 / E_2$  is known as **modular ratio** of the two materials.

**Example 4.11.** A bar 3 m long is made of two bars, one of copper having  $E = 105 \text{ GN/m}^2$  and the other of steel having  $E = 210 \text{ GN/m}^2$ . Each bar is 25 mm broad and 12.5 mm thick. This compound bar is stretched by a load of 50 kN. Find the increase in length of the compound bar and the stress produced in the steel and copper. The length of copper as well as of steel bar is 3 m each.

**Solution.** Given :  $l_c = l_s = 3 \text{ m} = 3 \times 10^3 \text{ mm}$  ;  $E_c = 105 \text{ GN/m}^2 = 105 \text{ kN/mm}^2$  ;  $E_s = 210 \text{ GN/m}^2 = 210 \text{ kN/mm}^2$  ;  $b = 25 \text{ mm}$  ;  $t = 12.5 \text{ mm}$  ;  $P = 50 \text{ kN}$

**Increase in length of the compound bar**

Let  $\delta l =$  Increase in length of the compound bar.

The compound bar is shown in Fig. 4.14. We know that cross-sectional area of each bar,

$$A_c = A_s = b \times t = 25 \times 12.5 = 312.5 \text{ mm}^2$$

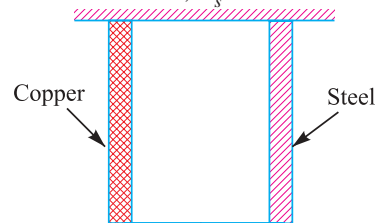

Fig. 4.14

## 104 ■ A Textbook of Machine Design

∴ Load shared by the copper bar,

$$P_c = P \times \frac{A_c \cdot E_c}{A_c \cdot E_c + A_s \cdot E_s} = P \times \frac{E_c}{E_c + E_s} \quad \dots (\because A_c = A_s)$$

$$= 50 \times \frac{105}{105 + 210} = 16.67 \text{ kN}$$

and load shared by the steel bar,

$$P_s = P - P_c = 50 - 16.67 = 33.33 \text{ kN}$$

Since the elongation of both the bars is equal, therefore

$$\delta l = \frac{P_c \cdot l_c}{A_c \cdot E_c} = \frac{P_s \cdot l_s}{A_s \cdot E_s} = \frac{16.67 \times 3 \times 10^3}{312.5 \times 105} = 1.52 \text{ mm Ans.}$$

### Stress produced in the steel and copper bar

We know that stress produced in the steel bar,

$$\sigma_s = \frac{E_s}{E_c} \times \sigma_c = \frac{210}{105} \times \sigma_c = 2 \sigma_c$$

and total load,

$$P = P_s + P_c = \sigma_s A_s + \sigma_c A_c$$

$$\therefore 50 = 2 \sigma_c \times 312.5 + \sigma_c \times 312.5 = 937.5 \sigma_c$$

or

$$\sigma_c = 50 / 937.5 = 0.053 \text{ kN/mm}^2 = 53 \text{ N/mm}^2 = 53 \text{ MPa Ans.}$$

and

$$\sigma_s = 2 \sigma_c = 2 \times 53 = 106 \text{ N/mm}^2 = 106 \text{ MPa Ans.}$$

**Example 4.12.** A central steel rod 18 mm diameter passes through a copper tube 24 mm inside and 40 mm outside diameter, as shown in Fig. 4.15. It is provided with nuts and washers at each end. The nuts are tightened until a stress of 10 MPa is set up in the steel.

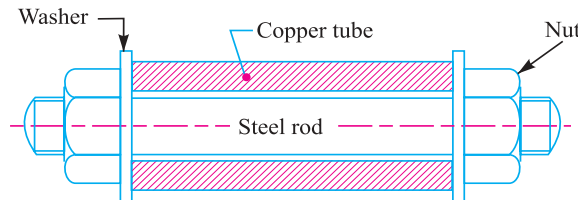

Fig. 4.15

The whole assembly is then placed in a lathe and turned along half the length of the tube removing the copper to a depth of 1.5 mm. Calculate the stress now existing in the steel. Take  $E_s = 2E_c$ .

**Solution.** Given :  $d_s = 18 \text{ mm}$  ;  $d_{c1} = 24 \text{ mm}$  ;  $d_{c2} = 40 \text{ mm}$  ;  $\sigma_s = 10 \text{ MPa} = 10 \text{ N/mm}^2$

We know that cross-sectional area of steel rod,

$$A_s = \frac{\pi}{4} (d_s)^2 = \frac{\pi}{4} (18)^2 = 254.5 \text{ mm}^2$$

and cross-sectional area of copper tube,

$$A_c = \frac{\pi}{4} [(d_{c2})^2 - (d_{c1})^2] = \frac{\pi}{4} [(40)^2 - (24)^2] = 804.4 \text{ mm}^2$$

We know that when the nuts are tightened on the tube, the steel rod will be under tension and the copper tube in compression.

Let  $\sigma_c =$  Stress in the copper tube.

Since the tensile load on the steel rod is equal to the compressive load on the copper tube, therefore

$$\sigma_s \times A_s = \sigma_c \times A_c$$

$$10 \times 254.5 = \sigma_c \times 804.4$$

$$\therefore \sigma_c = \frac{10 \times 254.5}{804.4} = 3.16 \text{ N/mm}^2$$

When the copper tube is reduced in the area for half of its length, then outside diameter of copper tube,

$$= 40 - 2 \times 1.5 = 37 \text{ mm}$$

$\therefore$  Cross-sectional area of the half length of copper tube,

$$A_{c1} = \frac{\pi}{4} (37^2 - 24^2) = 623 \text{ mm}^2$$

The cross-sectional area of the other half remains same. If  $A_{c2}$  be the area of the remainder, then

$$A_{c2} = A_c = 804.4 \text{ mm}^2$$

Let  $\sigma_{c1}$  = Compressive stress in the reduced section,  
 $\sigma_{c2}$  = Compressive stress in the remainder, and  
 $\sigma_{s1}$  = Stress in the rod after turning.

Since the load on the copper tube is equal to the load on the steel rod, therefore

$$A_{c1} \times \sigma_{c1} = A_{c2} \times \sigma_{c2} = A_s \times \sigma_{s1}$$

$$\therefore \sigma_{c1} = \frac{A_s}{A_{c1}} \times \sigma_{s1} = \frac{254.5}{623} \times \sigma_{s1} = 0.41 \sigma_{s1} \quad \dots(i)$$

and  $\sigma_{c2} = \frac{A_s}{A_{c2}} \times \sigma_{s1} = \frac{254.5}{804.4} \times \sigma_{s1} = 0.32 \sigma_{s1} \quad \dots(ii)$

Let  $\delta l$  = Change in length of the steel rod before and after turning,

$l$  = Length of the steel rod and copper tube between nuts,

$\delta l_1$  = Change in length of the reduced section (*i.e.*  $l/2$ ) before and after turning, and

$\delta l_2$  = Change in length of the remainder section (*i.e.*  $l/2$ ) before and after turning.

Since  $\delta l = \delta l_1 + \delta l_2$

$$\therefore \frac{\sigma_s - \sigma_{s1}}{E_s} \times l = \frac{\sigma_{c1} - \sigma_c}{E_c} \times \frac{l}{2} + \frac{\sigma_{c2} - \sigma_c}{E_c} \times \frac{l}{2}$$

or  $\frac{10 - \sigma_{s1}}{2E_c} = \frac{0.41 \sigma_{s1} - 3.16}{2E_c} + \frac{0.32 \sigma_{s1} - 3.16}{2E_c} \quad \dots(\text{Cancelling } l \text{ throughout})$

$$\therefore \sigma_{s1} = 9.43 \text{ N/mm}^2 = 9.43 \text{ MPa} \quad \text{Ans.}$$

#### 4.16 Stresses due to Change in Temperature—Thermal Stresses

Whenever there is some increase or decrease in the temperature of a body, it causes the body to expand or contract. A little consideration will show that if the body is allowed to expand or contract freely, with the rise or fall of the temperature, no stresses are induced in the body. But, if the deformation of the body is prevented, some stresses are induced in the body. Such stresses are known as **thermal stresses**.

## 106 ■ A Textbook of Machine Design

Let  $l$  = Original length of the body,  
 $t$  = Rise or fall of temperature, and  
 $\alpha$  = Coefficient of thermal expansion,

$\therefore$  Increase or decrease in length,  
 $\delta l = l \cdot \alpha \cdot t$

If the ends of the body are fixed to rigid supports, so that its expansion is prevented, then compressive strain induced in the body,

$$\epsilon_c = \frac{\delta l}{l} = \frac{l \cdot \alpha \cdot t}{l} = \alpha \cdot t$$

$\therefore$  Thermal stress,  $\sigma_{th} = \epsilon_c \cdot E = \alpha \cdot t \cdot E$

**Notes : 1.** When a body is composed of two or different materials having different coefficient of thermal expansions, then due to the rise in temperature, the material with higher coefficient of thermal expansion will be subjected to compressive stress whereas the material with low coefficient of expansion will be subjected to tensile stress.

**2.** When a thin tyre is shrunk on to a wheel of diameter  $D$ , its internal diameter  $d$  is a little less than the wheel diameter. When the tyre is heated, its circumference  $\pi d$  will increase to  $\pi D$ . In this condition, it is slipped on to the wheel. When it cools, it wants to return to its original circumference  $\pi d$ , but the wheel if it is assumed to be rigid, prevents it from doing so.

$$\therefore \text{Strain, } \epsilon = \frac{\pi D - \pi d}{\pi d} = \frac{D - d}{d}$$

This strain is known as *circumferential* or *hoop strain*.

$\therefore$  Circumferential or hoop stress,

$$\sigma = E \cdot \epsilon = \frac{E(D - d)}{d}$$

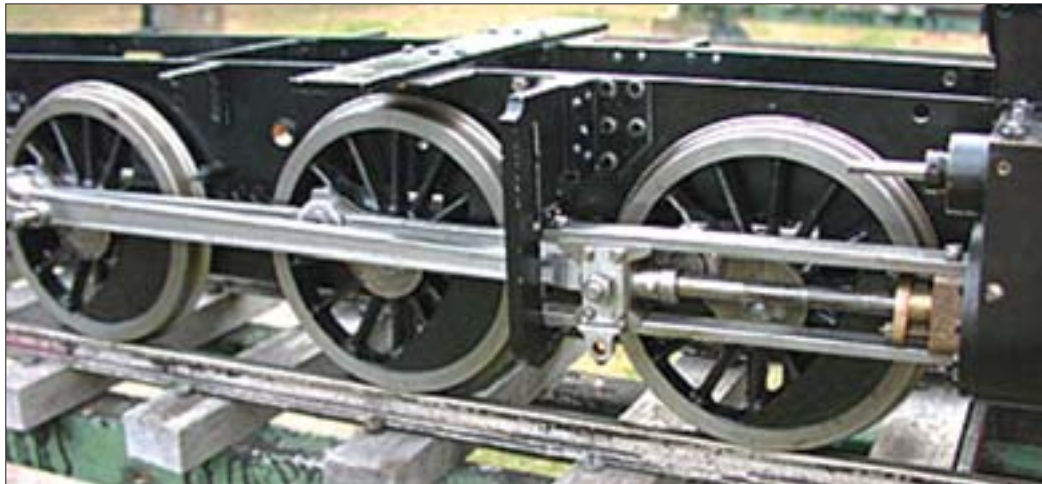

Steel tyres of a locomotive.

**Example 4.13.** A thin steel tyre is shrunk on to a locomotive wheel of 1.2 m diameter. Find the internal diameter of the tyre if after shrinking on, the hoop stress in the tyre is 100 MPa. Assume  $E = 200 \text{ kN/mm}^2$ . Find also the least temperature to which the tyre must be heated above that of the wheel before it could be slipped on. The coefficient of linear expansion for the tyre is  $6.5 \times 10^{-6}$  per  $^\circ\text{C}$ .

**Solution.** Given :  $D = 1.2 \text{ m} = 1200 \text{ mm}$  ;  $\sigma = 100 \text{ MPa} = 100 \text{ N/mm}^2$  ;  $E = 200 \text{ kN/mm}^2 = 200 \times 10^3 \text{ N/mm}^2$  ;  $\alpha = 6.5 \times 10^{-6}$  per  $^\circ\text{C}$

**Internal diameter of the tyre**

Let  $d$  = Internal diameter of the tyre.

We know that hoop stress ( $\sigma$ ),

$$100 = \frac{E(D-d)}{d} = \frac{200 \times 10^3(D-d)}{d}$$

$$\therefore \frac{D-d}{d} = \frac{100}{200 \times 10^3} = \frac{1}{2 \times 10^3} \quad \dots(i)$$

$$\frac{D}{d} = 1 + \frac{1}{2 \times 10^3} = 1.0005$$

$$\therefore d = \frac{D}{1.0005} = \frac{1200}{1.0005} = 1199.4 \text{ mm} = 1.1994 \text{ m} \quad \text{Ans.}$$

**Least temperature to which the tyre must be heated**

Let  $t$  = Least temperature to which the tyre must be heated.

We know that

$$\pi D = \pi d + \pi d \cdot \alpha \cdot t = \pi d(1 + \alpha \cdot t)$$

$$\alpha \cdot t = \frac{\pi D}{\pi d} - 1 = \frac{D-d}{d} = \frac{1}{2 \times 10^3} \quad \dots[\text{From equation (i)}]$$

$$\therefore t = \frac{1}{\alpha \times 2 \times 10^3} = \frac{1}{6.5 \times 10^{-6} \times 2 \times 10^3} = 77^\circ\text{C} \quad \text{Ans.}$$

**Example 4.14.** A composite bar made of aluminium and steel is held between the supports as shown in Fig. 4.16. The bars are stress free at a temperature of  $37^\circ\text{C}$ . What will be the stress in the two bars when the temperature is  $20^\circ\text{C}$ , if (a) the supports are unyielding; and (b) the supports yield and come nearer to each other by 0.10 mm?

It can be assumed that the change of temperature is uniform all along the length of the bar. Take  $E_s = 210 \text{ GPa}$ ;  $E_a = 74 \text{ GPa}$ ;  $\alpha_s = 11.7 \times 10^{-6} / ^\circ\text{C}$ ; and  $\alpha_a = 23.4 \times 10^{-6} / ^\circ\text{C}$ .

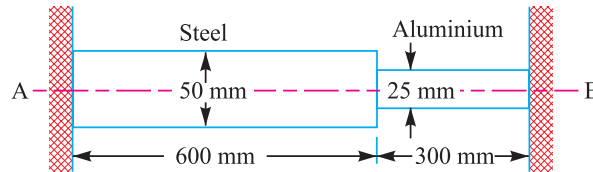

**Fig. 4.16**

**Solution.** Given :  $t_1 = 37^\circ\text{C}$ ;  $t_2 = 20^\circ\text{C}$ ;  $E_s = 210 \text{ GPa} = 210 \times 10^9 \text{ N/m}^2$ ;  $E_a = 74 \text{ GPa} = 74 \times 10^9 \text{ N/m}^2$ ;  $\alpha_s = 11.7 \times 10^{-6} / ^\circ\text{C}$ ;  $\alpha_a = 23.4 \times 10^{-6} / ^\circ\text{C}$ ,  $d_s = 50 \text{ mm} = 0.05 \text{ m}$ ;  $d_a = 25 \text{ mm} = 0.025 \text{ m}$ ;  $l_s = 600 \text{ mm} = 0.6 \text{ m}$ ;  $l_a = 300 \text{ mm} = 0.3 \text{ m}$

Let us assume that the right support at B is removed and the bar is allowed to contract freely due to the fall in temperature. We know that the fall in temperature,

$$t = t_1 - t_2 = 37 - 20 = 17^\circ\text{C}$$

$\therefore$  Contraction in steel bar

$$= \alpha_s \cdot l_s \cdot t = 11.7 \times 10^{-6} \times 600 \times 17 = 0.12 \text{ mm}$$

and contraction in aluminium bar

$$= \alpha_a \cdot l_a \cdot t = 23.4 \times 10^{-6} \times 300 \times 17 = 0.12 \text{ mm}$$

$$\text{Total contraction} = 0.12 + 0.12 = 0.24 \text{ mm} = 0.24 \times 10^{-3} \text{ m}$$

It may be noted that even after this contraction (*i.e.* 0.24 mm) in length, the bar is still stress free as the right hand end was assumed free.

## 108 ■ A Textbook of Machine Design

Let an axial force  $P$  is applied to the right end till this end is brought in contact with the right hand support at  $B$ , as shown in Fig. 4.17.

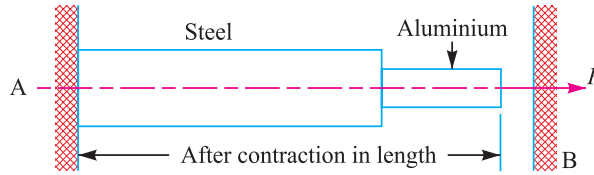

Fig. 4.17

We know that cross-sectional area of the steel bar,

$$A_s = \frac{\pi}{4} (d_s)^2 = \frac{\pi}{4} (0.05)^2 = 1.964 \times 10^{-3} \text{ m}^2$$

and cross-sectional area of the aluminium bar,

$$A_a = \frac{\pi}{4} (d_a)^2 = \frac{\pi}{4} (0.025)^2 = 0.491 \times 10^{-3} \text{ m}^2$$

We know that elongation of the steel bar,

$$\begin{aligned} \delta l_s &= \frac{P \times l_s}{A_s \times E_s} = \frac{P \times 0.6}{1.964 \times 10^{-3} \times 210 \times 10^9} = \frac{0.6P}{412.44 \times 10^6} \text{ m} \\ &= 1.455 \times 10^{-9} P \text{ m} \end{aligned}$$

and elongation of the aluminium bar,

$$\begin{aligned} \delta l_a &= \frac{P \times l_a}{A_a \times E_a} = \frac{P \times 0.3}{0.491 \times 10^{-3} \times 74 \times 10^9} = \frac{0.3P}{36.334 \times 10^6} \text{ m} \\ &= 8.257 \times 10^{-9} P \text{ m} \end{aligned}$$

∴ Total elongation,

$$\begin{aligned} \delta l &= \delta l_s + \delta l_a \\ &= 1.455 \times 10^{-9} P + 8.257 \times 10^{-9} P = 9.712 \times 10^{-9} P \text{ m} \end{aligned}$$

Let

$\sigma_s$  = Stress in the steel bar, and

$\sigma_a$  = Stress in the aluminium bar.

### (a) When the supports are unyielding

When the supports are unyielding, the total contraction is equated to the total elongation, i.e.

$$0.24 \times 10^{-3} = 9.712 \times 10^{-9} P \quad \text{or} \quad P = 24\,712 \text{ N}$$

∴ Stress in the steel bar,

$$\begin{aligned} \sigma_s &= P/A_s = 24\,712 / (1.964 \times 10^{-3}) = 12\,582 \times 10^3 \text{ N/m}^2 \\ &= 12.582 \text{ MPa} \quad \text{Ans.} \end{aligned}$$

and stress in the aluminium bar,

$$\begin{aligned} \sigma_a &= P/A_a = 24\,712 / (0.491 \times 10^{-3}) = 50\,328 \times 10^3 \text{ N/m}^2 \\ &= 50.328 \text{ MPa} \quad \text{Ans.} \end{aligned}$$

### (b) When the supports yield by 0.1 mm

When the supports yield and come nearer to each other by 0.10 mm, the net contraction in length

$$= 0.24 - 0.1 = 0.14 \text{ mm} = 0.14 \times 10^{-3} \text{ m}$$

Equating this net contraction to the total elongation, we have

$$0.14 \times 10^{-3} = 9.712 \times 10^{-9} P \quad \text{or} \quad P = 14\,415 \text{ N}$$

∴ Stress in the steel bar,

$$\begin{aligned} \sigma_s &= P/A_s = 14\,415 / (1.964 \times 10^{-3}) = 7340 \times 10^3 \text{ N/m}^2 \\ &= 7.34 \text{ MPa} \quad \text{Ans.} \end{aligned}$$

and stress in the aluminium bar,

$$\begin{aligned} \sigma_a &= P/A_a = 14\,415 / (0.491 \times 10^{-3}) = 29\,360 \times 10^3 \text{ N/m}^2 \\ &= 29.36 \text{ MPa} \quad \text{Ans.} \end{aligned}$$

**Example 4.15.** A copper bar 50 mm in diameter is placed within a steel tube 75 mm external diameter and 50 mm internal diameter of exactly the same length. The two pieces are rigidly fixed together by two pins 18 mm in diameter, one at each end passing through the bar and tube. Calculate the stress induced in the copper bar, steel tube and pins if the temperature of the combination is raised by 50°C. Take  $E_s = 210 \text{ GN/m}^2$ ;  $E_c = 105 \text{ GN/m}^2$ ;  $\alpha_s = 11.5 \times 10^{-6}/^\circ\text{C}$  and  $\alpha_c = 17 \times 10^{-6}/^\circ\text{C}$ .

**Solution.** Given:  $d_c = 50 \text{ mm}$ ;  $d_{se} = 75 \text{ mm}$ ;  $d_{si} = 50 \text{ mm}$ ;  $d_p = 18 \text{ mm} = 0.018 \text{ m}$ ;  $t = 50^\circ\text{C}$ ;  $E_s = 210 \text{ GN/m}^2 = 210 \times 10^9 \text{ N/m}^2$ ;  $E_c = 105 \text{ GN/m}^2 = 105 \times 10^9 \text{ N/m}^2$ ;  $\alpha_s = 11.5 \times 10^{-6}/^\circ\text{C}$ ;  $\alpha_c = 17 \times 10^{-6}/^\circ\text{C}$

The copper bar in a steel tube is shown in Fig. 4.18.

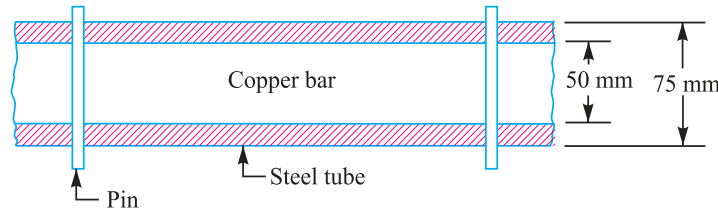

Fig. 4.18

We know that cross-sectional area of the copper bar,

$$A_c = \frac{\pi}{4} (d_c)^2 = \frac{\pi}{4} (50)^2 = 1964 \text{ mm}^2 = 1964 \times 10^{-6} \text{ m}^2$$

and cross-sectional area of the steel tube,

$$\begin{aligned} A_s &= \frac{\pi}{4} [(d_{se})^2 - (d_{si})^2] = \frac{\pi}{4} [(75)^2 - (50)^2] = 2455 \text{ mm}^2 \\ &= 2455 \times 10^{-6} \text{ m}^2 \end{aligned}$$

Let  $l$  = Length of the copper bar and steel tube.

We know that free expansion of copper bar

$$= \alpha_c \cdot l \cdot t = 17 \times 10^{-6} \times l \times 50 = 850 \times 10^{-6} l$$

and free expansion of steel tube

$$= \alpha_s \cdot l \cdot t = 11.5 \times 10^{-6} \times l \times 50 = 575 \times 10^{-6} l$$

∴ Difference in free expansion

$$= 850 \times 10^{-6} l - 575 \times 10^{-6} l = 275 \times 10^{-6} l \quad \dots(i)$$

## 110 ■ A Textbook of Machine Design

Since the free expansion of the copper bar is more than the free expansion of the steel tube, therefore the copper bar is subjected to a \*compressive stress, while the steel tube is subjected to a tensile stress.

Let a compressive force  $P$  newton on the copper bar opposes the extra expansion of the copper bar and an equal tensile force  $P$  on the steel tube pulls the steel tube so that the net effect of reduction in length of copper bar and the increase in length of steel tube equalises the difference in free expansion of the two.

∴ Reduction in length of copper bar due to force  $P$

$$\begin{aligned} &= \frac{P \cdot l}{A_c \cdot E_c} \\ &= \frac{P \cdot l}{1964 \times 10^{-6} \times 105 \times 10^9} = \frac{P \cdot l}{206.22 \times 10^6} \text{ m} \end{aligned}$$

and increase in length of steel bar due to force  $P$

$$= \frac{P \cdot l}{A_s \cdot E_s} = \frac{P \cdot l}{2455 \times 10^{-6} \times 210 \times 10^9} = \frac{P \cdot l}{515.55 \times 10^6} \text{ m}$$

$$\begin{aligned} \therefore \text{Net effect in length} &= \frac{P \cdot l}{206.22 \times 10^6} + \frac{P \cdot l}{515.55 \times 10^6} \\ &= 4.85 \times 10^{-9} P \cdot l + 1.94 \times 10^{-9} P \cdot l = 6.79 \times 10^{-9} P \cdot l \end{aligned}$$

Equating this net effect in length to the difference in free expansion, we have

$$6.79 \times 10^{-9} P \cdot l = 275 \times 10^{-6} l \quad \text{or} \quad P = 40\,500 \text{ N}$$

### **Stress induced in the copper bar, steel tube and pins**

We know that stress induced in the copper bar,

$$\sigma_c = P / A_c = 40\,500 / (1964 \times 10^{-6}) = 20.62 \times 10^6 \text{ N/m}^2 = 20.62 \text{ MPa} \quad \text{Ans.}$$

Stress induced in the steel tube,

$$\sigma_s = P / A_s = 40\,500 / (2455 \times 10^{-6}) = 16.5 \times 10^6 \text{ N/m}^2 = 16.5 \text{ MPa} \quad \text{Ans.}$$



*Main wheels on the undercarriage of an airliner. Air plane landing gears and wheels need to bear high stresses and shocks.*

**Note :** This picture is given as additional information and is not a direct example of the current chapter.

\* In other words, we can also say that since the coefficient of thermal expansion for copper ( $\alpha_c$ ) is more than the coefficient of thermal expansion for steel ( $\alpha_s$ ), therefore the copper bar will be subjected to compressive stress and the steel tube will be subjected to tensile stress.



and shear stress induced in the pins,

$$\tau_p = \frac{P}{2 A_p} = \frac{40500}{2 \times \frac{\pi}{4} (0.018)^2} = 79.57 \times 10^6 \text{ N/m}^2 = 79.57 \text{ MPa} \text{ Ans.}$$

...(: The pin is in double shear )

### 4.17 Linear and Lateral Strain

Consider a circular bar of diameter  $d$  and length  $l$ , subjected to a tensile force  $P$  as shown in Fig. 4.19 (a).

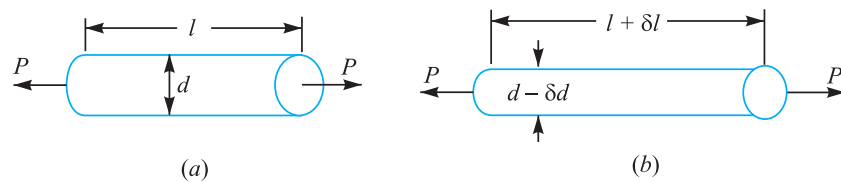

Fig. 4.19. Linear and lateral strain.

A little consideration will show that due to tensile force, the length of the bar increases by an amount  $\delta l$  and the diameter decreases by an amount  $\delta d$ , as shown in Fig. 4.19 (b). Similarly, if the bar is subjected to a compressive force, the length of bar will decrease which will be followed by increase in diameter.

It is thus obvious, that every direct stress is accompanied by a strain in its own direction which is known as **linear strain** and an opposite kind of strain in every direction, at right angles to it, is known as **lateral strain**.

### 4.18 Poisson's Ratio

It has been found experimentally that when a body is stressed within elastic limit, the lateral strain bears a constant ratio to the linear strain, Mathematically,

$$\frac{\text{Lateral strain}}{\text{Linear strain}} = \text{Constant}$$

This constant is known as **Poisson's ratio** and is denoted by  $1/m$  or  $\mu$ .

Following are the values of Poisson's ratio for some of the materials commonly used in engineering practice.

Table 4.4. Values of Poisson's ratio for commonly used materials.

| S.No. | Material  | Poisson's ratio ( $1/m$ or $\mu$ ) |
|-------|-----------|------------------------------------|
| 1     | Steel     | 0.25 to 0.33                       |
| 2     | Cast iron | 0.23 to 0.27                       |
| 3     | Copper    | 0.31 to 0.34                       |
| 4     | Brass     | 0.32 to 0.42                       |
| 5     | Aluminium | 0.32 to 0.36                       |
| 6     | Concrete  | 0.08 to 0.18                       |
| 7     | Rubber    | 0.45 to 0.50                       |

### 4.19 Volumetric Strain

When a body is subjected to a system of forces, it undergoes some changes in its dimensions. In other words, the volume of the body is changed. The ratio of the change in volume to the original volume is known as **volumetric strain**. Mathematically, volumetric strain,

$$\epsilon_v = \delta V / V$$

where  $\delta V =$  Change in volume, and  $V =$  Original volume.

**Notes : 1.** Volumetric strain of a rectangular body subjected to an axial force is given as

$$\epsilon_v = \frac{\delta V}{V} = \epsilon \left( 1 - \frac{2}{m} \right); \text{ where } \epsilon = \text{Linear strain.}$$

**2.** Volumetric strain of a rectangular body subjected to three mutually perpendicular forces is given by

$$\epsilon_v = \epsilon_x + \epsilon_y + \epsilon_z$$

where  $\epsilon_x$ ,  $\epsilon_y$  and  $\epsilon_z$  are the strains in the directions  $x$ -axis,  $y$ -axis and  $z$ -axis respectively.

### 4.20 Bulk Modulus

When a body is subjected to three mutually perpendicular stresses, of equal intensity, then the ratio of the direct stress to the corresponding volumetric strain is known as **bulk modulus**. It is usually denoted by  $K$ . Mathematically, bulk modulus,

$$K = \frac{\text{Direct stress}}{\text{Volumetric strain}} = \frac{\sigma}{\delta V / V}$$

### 4.21 Relation Between Bulk Modulus and Young's Modulus

The bulk modulus ( $K$ ) and Young's modulus ( $E$ ) are related by the following relation,

$$K = \frac{m.E}{3(m-2)} = \frac{E}{3(1-2\mu)}$$

### 4.22 Relation Between Young's Modulus and Modulus of Rigidity

The Young's modulus ( $E$ ) and modulus of rigidity ( $G$ ) are related by the following relation,

$$G = \frac{m.E}{2(m+1)} = \frac{E}{2(1+\mu)}$$

**Example 4.16.** A mild steel rod supports a tensile load of 50 kN. If the stress in the rod is limited to 100 MPa, find the size of the rod when the cross-section is 1. circular, 2. square, and 3. rectangular with width = 3 × thickness.

**Solution.** Given :  $P = 50 \text{ kN} = 50 \times 10^3 \text{ N}$  ;  $\sigma_t = 100 \text{ MPa} = 100 \text{ N/mm}^2$

#### 1. Size of the rod when it is circular

Let  $d =$  Diameter of the rod in mm.

$$\therefore \text{Area, } A = \frac{\pi}{4} \times d^2 = 0.7854 d^2$$

We know that tensile load ( $P$ ),

$$50 \times 10^3 = \sigma_t \times A = 100 \times 0.7854 d^2 = 78.54 d^2$$

$$\therefore d^2 = 50 \times 10^3 / 78.54 = 636.6 \text{ or } d = 25.23 \text{ mm Ans.}$$

**2. Size of the rod when it is square**

Let  $x$  = Each side of the square rod in mm.  
 $\therefore$  Area,  $A = x \times x = x^2$   
 We know that tensile load ( $P$ ),  
 $50 \times 10^3 = \sigma_t \times A = 100 \times x^2$   
 $\therefore x^2 = 50 \times 10^3 / 100 = 500$  or  $x = 22.4$  mm **Ans.**

**3. Size of the rod when it is rectangular**

Let  $t$  = Thickness of the rod in mm, and  
 $b$  = Width of the rod in mm =  $3t$  ... (Given)  
 $\therefore$  Area,  $A = b \times t = 3t \times t = 3t^2$   
 We know that tensile load ( $P$ ),  
 $50 \times 10^3 = \sigma_t \times A = 100 \times 3t^2 = 300t^2$   
 $\therefore t^2 = 50 \times 10^3 / 300 = 166.7$  or  $t = 12.9$  mm **Ans.**  
 and  $b = 3t = 3 \times 12.9 = 38.7$  mm **Ans.**

**Example 4.17.** A steel bar 2.4 m long and 30 mm square is elongated by a load of 500 kN. If poisson's ratio is 0.25, find the increase in volume. Take  $E = 0.2 \times 10^6$  N/mm<sup>2</sup>.

**Solution.** Given :  $l = 2.4$  m = 2400 mm ;  $A = 30 \times 30 = 900$  mm<sup>2</sup> ;  $P = 500$  kN =  $500 \times 10^3$  N ;  $l/m = 0.25$  ;  $E = 0.2 \times 10^6$  N/mm<sup>2</sup>

Let  $\delta V$  = Increase in volume.

We know that volume of the rod,

$$V = \text{Area} \times \text{length} = 900 \times 2400 = 2160 \times 10^3 \text{ mm}^3$$

and Young's modulus,  $E = \frac{\text{Stress}}{\text{Strain}} = \frac{P/A}{\epsilon}$

$$\therefore \epsilon = \frac{P}{A.E} = \frac{500 \times 10^3}{900 \times 0.2 \times 10^6} = 2.8 \times 10^{-3}$$

We know that volumetric strain,

$$\frac{\delta V}{V} = \epsilon \left( 1 - \frac{2}{m} \right) = 2.8 \times 10^{-3} (1 - 2 \times 0.25) = 1.4 \times 10^{-3}$$

$$\therefore \delta V = V \times 1.4 \times 10^{-3} = 2160 \times 10^3 \times 1.4 \times 10^{-3} = 3024 \text{ mm}^3 \text{ Ans.}$$

**4.23 Impact Stress**

Sometimes, machine members are subjected to the load with impact. The stress produced in the member due to the falling load is known as **impact stress**.

Consider a bar carrying a load  $W$  at a height  $h$  and falling on the collar provided at the lower end, as shown in Fig. 4.20.

- Let  $A$  = Cross-sectional area of the bar,
- $E$  = Young's modulus of the material of the bar,
- $l$  = Length of the bar,
- $\delta l$  = Deformation of the bar,
- $P$  = Force at which the deflection  $\delta l$  is produced,
- $\sigma_t$  = Stress induced in the bar due to the application of impact load, and
- $h$  = Height through which the load falls.

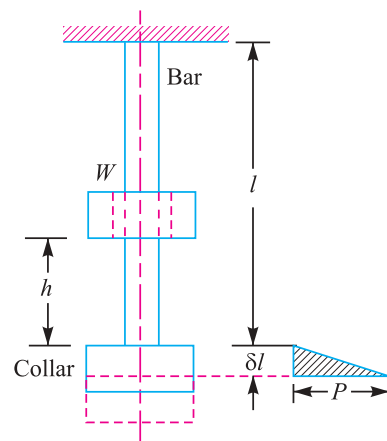

**Fig. 4.20.** Impact stress.

## 114 ■ A Textbook of Machine Design

We know that energy gained by the system in the form of strain energy

$$= \frac{1}{2} \times P \times \delta l$$

and potential energy lost by the weight

$$= W(h + \delta l)$$

Since the energy gained by the system is equal to the potential energy lost by the weight, therefore

$$\frac{1}{2} \times P \times \delta l = W(h + \delta l)$$

$$\frac{1}{2} \sigma_i \times A \times \frac{\sigma_i \times l}{E} = W \left( h + \frac{\sigma_i \times l}{E} \right) \quad \dots \left[ \because P = \sigma_i \times A, \text{ and } \delta l = \frac{\sigma_i \times l}{E} \right]$$

$$\therefore \frac{A l}{2 E} (\sigma_i)^2 - \frac{W l}{E} (\sigma_i) - W h = 0$$

From this quadratic equation, we find that

$$\sigma_i = \frac{W}{A} \left( 1 + \sqrt{1 + \frac{2 h A E}{W l}} \right) \quad \dots \text{ [Taking +ve sign for maximum value]}$$

**Note :** When  $h = 0$ , then  $\sigma_i = 2W/A$ . This means that the stress in the bar when the load is applied suddenly is double of the stress induced due to gradually applied load.

**Example 4.18.** An unknown weight falls through 10 mm on a collar rigidly attached to the lower end of a vertical bar 3 m long and 600 mm<sup>2</sup> in section. If the maximum instantaneous extension is known to be 2 mm, what is the corresponding stress and the value of unknown weight? Take  $E = 200 \text{ kN/mm}^2$ .

**Solution.** Given :  $h = 10 \text{ mm}$  ;  $l = 3 \text{ m} = 3000 \text{ mm}$  ;  $A = 600 \text{ mm}^2$  ;  $\delta l = 2 \text{ mm}$  ;  
 $E = 200 \text{ kN/mm}^2 = 200 \times 10^3 \text{ N/mm}^2$

### Stress in the bar

Let  $\sigma =$  Stress in the bar.

We know that Young's modulus,

$$E = \frac{\text{Stress}}{\text{Strain}} = \frac{\sigma}{\epsilon} = \frac{\sigma \cdot l}{\delta l}$$

$$\therefore \sigma = \frac{E \cdot \delta l}{l} = \frac{200 \times 10^3 \times 2}{3000} = \frac{400}{3} = 133.3 \text{ N/mm}^2 \quad \text{Ans.}$$



These bridge shoes are made to bear high compressive stresses.

**Note :** This picture is given as additional information and is not a direct example of the current chapter.

**Value of the unknown weight**

Let  $W$  = Value of the unknown weight.

We know that 
$$\sigma = \frac{W}{A} \left[ 1 + \sqrt{1 + \frac{2hAE}{Wl}} \right]$$

$$\frac{400}{3} = \frac{W}{600} \left[ 1 + \sqrt{1 + \frac{2 \times 10 \times 600 \times 200 \times 10^3}{W \times 3000}} \right]$$

$$\frac{400 \times 600}{3W} = 1 + \sqrt{1 + \frac{800\,000}{W}}$$

$$\frac{80\,000}{W} - 1 = \sqrt{1 + \frac{800\,000}{W}}$$

Squaring both sides,

$$\frac{6400 \times 10^6}{W^2} + 1 - \frac{160\,000}{W} = 1 + \frac{800\,000}{W}$$

$$\frac{6400 \times 10^2}{W} - 16 = 80 \quad \text{or} \quad \frac{6400 \times 10^2}{W} = 96$$

$$\therefore W = 6400 \times 10^2 / 96 = 6666.7 \text{ N } \mathbf{Ans.}$$

**4.24 Resilience**

When a body is loaded within elastic limit, it changes its dimensions and on the removal of the load, it regains its original dimensions. So long as it remains loaded, it has stored energy in itself. On removing the load, the energy stored is given off as in the case of a spring. This energy, which is absorbed in a body when strained within elastic limit, is known as **strain energy**. The strain energy is always capable of doing some work.

The strain energy stored in a body due to external loading, within elastic limit, is known as **resilience** and the maximum energy which can be stored in a body up to the elastic limit is called **proof resilience**. The proof resilience per unit volume of a material is known as **modulus of resilience**. It is an important property of a material and gives capacity of the material to bear impact or shocks. Mathematically, strain energy stored in a body due to tensile or compressive load or resilience,

$$U = \frac{\sigma^2 \times V}{2E}$$

and Modulus of resilience =  $\frac{\sigma^2}{2E}$

where  $\sigma$  = Tensile or compressive stress,

$V$  = Volume of the body, and

$E$  = Young's modulus of the material of the body.

**Notes : 1.** When a body is subjected to a shear load, then modulus of resilience (shear)

$$= \frac{\tau^2}{2C}$$

where  $\tau$  = Shear stress, and

$C$  = Modulus of rigidity.

**2.** When the body is subjected to torsion, then modulus of resilience

$$= \frac{\tau^2}{4C}$$

## 116 ■ A Textbook of Machine Design

**Example 4.19.** A wrought iron bar 50 mm in diameter and 2.5 m long transmits a shock energy of 100 N-m. Find the maximum instantaneous stress and the elongation. Take  $E = 200 \text{ GN/m}^2$ .

**Solution.** Given :  $d = 50 \text{ mm}$  ;  $l = 2.5 \text{ m} = 2500 \text{ mm}$  ;  $U = 100 \text{ N-m} = 100 \times 10^3 \text{ N-mm}$  ;  
 $E = 200 \text{ GN/m}^2 = 200 \times 10^3 \text{ N/mm}^2$

**Maximum instantaneous stress**

Let  $\sigma =$  Maximum instantaneous stress.

We know that volume of the bar,

$$V = \frac{\pi}{4} \times d^2 \times l = \frac{\pi}{4} (50)^2 \times 2500 = 4.9 \times 10^6 \text{ mm}^3$$

We also know that shock or strain energy stored in the body ( $U$ ),

$$100 \times 10^3 = \frac{\sigma^2 \times V}{2E} = \frac{\sigma^2 \times 4.9 \times 10^6}{2 \times 200 \times 10^3} = 12.25 \sigma^2$$

$$\therefore \sigma^2 = 100 \times 10^3 / 12.25 = 8163 \quad \text{or} \quad \sigma = 90.3 \text{ N/mm}^2 \text{ Ans.}$$

**Elongation produced**

Let  $\delta l =$  Elongation produced.

We know that Young's modulus,

$$E = \frac{\text{Stress}}{\text{Strain}} = \frac{\sigma}{\epsilon} = \frac{\sigma}{\delta l / l}$$

$$\therefore \delta l = \frac{\sigma \times l}{E} = \frac{90.3 \times 2500}{200 \times 10^3} = 1.13 \text{ mm} \text{ Ans.}$$



A double-decker train.

### EXERCISES

1. A reciprocating steam engine connecting rod is subjected to a maximum load of 65 kN. Find the diameter of the connecting rod at its thinnest part, if the permissible tensile stress is 35 N/mm<sup>2</sup>.  
[Ans. 50 mm]
2. The maximum tension in the lower link of a Porter governor is 580 N and the maximum stress in the link is 30 N/mm<sup>2</sup>. If the link is of circular cross-section, determine its diameter.  
[Ans. 5 mm]

3. A wrought iron rod is under a compressive load of 350 kN. If the permissible stress for the material is  $52.5 \text{ N/mm}^2$ , calculate the diameter of the rod. [Ans. 95 mm]
4. A load of 5 kN is to be raised by means of a steel wire. Find the minimum diameter required, if the stress in the wire is not to exceed  $100 \text{ N/mm}^2$ . [Ans. 8 mm]
5. A square tie bar  $20 \text{ mm} \times 20 \text{ mm}$  in section carries a load. It is attached to a bracket by means of 6 bolts. Calculate the diameter of the bolt if the maximum stress in the tie bar is  $150 \text{ N/mm}^2$  and in the bolts is  $75 \text{ N/mm}^2$ . [Ans. 13 mm]
6. The diameter of a piston of the steam engine is 300 mm and the maximum steam pressure is  $0.7 \text{ N/mm}^2$ . If the maximum permissible compressive stress for the piston rod material is  $40 \text{ N/mm}^2$ , find the size of the piston rod. [Ans. 40 mm]
7. Two circular rods of 50 mm diameter are connected by a knuckle joint, as shown in Fig. 4.21, by a pin of 40 mm in diameter. If a pull of 120 kN acts at each end, find the tensile stress in the rod and shear stress in the pin. [Ans.  $61 \text{ N/mm}^2$ ;  $48 \text{ N/mm}^2$ ]

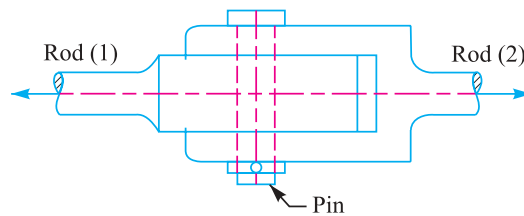

Fig. 4.21

8. Find the minimum size of a hole that can be punched in a 20 mm thick mild steel plate having an ultimate shear strength of  $300 \text{ N/mm}^2$ . The maximum permissible compressive stress in the punch material is  $1200 \text{ N/mm}^2$ . [Ans. 20 mm]
9. The crankpin of an engine sustains a maximum load of 35 kN due to steam pressure. If the allowable bearing pressure is  $7 \text{ N/mm}^2$ , find the dimensions of the pin. Assume the length of the pin equal to 1.2 times the diameter of the pin. [Ans. 64.5 mm; 80 mm]
10. The following results were obtained in a tensile test on a mild steel specimen of original diameter 20 mm and gauge length 40 mm.
 

|                                  |   |          |
|----------------------------------|---|----------|
| Load at limit of proportionality | = | 80 kN    |
| Extension at 80 kN load          | = | 0.048 mm |
| Load at yield point              | = | 85 kN    |
| Maximum load                     | = | 150 kN   |

When the two parts were fitted together after being broken, the length between gauge length was found to be 55.6 mm and the diameter at the neck was 15.8 mm.

Calculate Young's modulus, yield stress, ultimate tensile stress, percentage elongation and percentage reduction in area. [Ans.  $213 \text{ kN/mm}^2$ ;  $270 \text{ N/mm}^2$ ;  $478 \text{ N/mm}^2$ ; 39%; 38%]

11. A steel rod of 25 mm diameter is fitted inside a brass tube of 25 mm internal diameter and 375 mm external diameter. The projecting ends of the steel rod are provided with nuts and washers. The nuts are tightened up so as to produce a pull of 5 kN in the rod. The compound is then placed in a lathe and the brass is turned down to 4 mm thickness. Calculate the stresses in the two materials. [Ans.  $7 \text{ N/mm}^2$ ,  $7.8 \text{ N/mm}^2$ ]

## 118 ■ A Textbook of Machine Design

12. A composite bar made up of aluminium bar and steel bar, is firmly held between two unyielding supports as shown in Fig. 4.22.

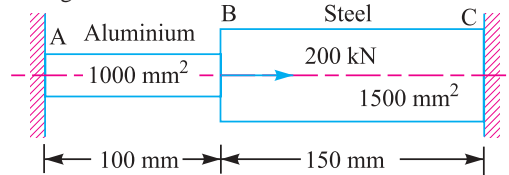

Fig. 4.22

An axial load of 200 kN is applied at B at 47°C. Find the stresses in each material, when the temperature is 97°C. Take  $E_a = 70$  GPa ;  $E_s = 210$  GPa ;  $\alpha_a = 24 \times 10^{-6}/^\circ\text{C}$  and  $\alpha_s = 12 \times 10^{-6}/^\circ\text{C}$ .

[Ans. 60.3 MPa; 173.5 MPa]

13. A steel rod of 20 mm diameter passes centrally through a copper tube of external diameter 40 mm and internal diameter 20 mm. The tube is closed at each end with the help of rigid washers (of negligible thickness) which are screwed by the nuts. The nuts are tightened until the compressive load on the copper tube is 50 kN. Determine the stresses in the rod and the tube, when the temperature of whole assembly falls by 50°C. Take  $E_s = 200$  GPa ;  $E_c = 100$  GPa ;  $\alpha_s = 12 \times 10^{-6}/^\circ\text{C}$  and  $\alpha_c = 18 \times 10^{-6}/^\circ\text{C}$ .
14. A bar of 2 m length, 20 mm breadth and 15 mm thickness is subjected to a tensile load of 30 kN. Find the final volume of the bar, if the Poisson's ratio is 0.25 and Young's modulus is 200 GN/m<sup>2</sup>.
15. A bar of 12 mm diameter gets stretched by 3 mm under a steady load of 8 kN. What stress would be produced in the bar by a weight of 800 N, which falls through 80 mm before commencing the stretching of the rod, which is initially unstressed. Take  $E = 200$  kN/mm<sup>2</sup>.

[Ans. 99.6 MPa; 19.8 MPa]

[Ans. 600 150 mm<sup>3</sup>]

[Ans. 170.6 N/mm<sup>2</sup>]

### QUESTIONS

- Define the terms load, stress and strain. Discuss the various types of stresses and strain.
- What is the difference between modulus of elasticity and modulus of rigidity?
- Explain clearly the bearing stress developed at the area of contact between two members.
- What useful informations are obtained from the tensile test of a ductile material?
- What do you mean by factor of safety?
- List the important factors that influence the magnitude of factor of safety.
- What is meant by working stress and how it is calculated from the ultimate stress or yield stress of a material? What will be the factor of safety in each case for different types of loading?
- Describe the procedure for finding out the stresses in a composite bar.
- Explain the difference between linear and lateral strain.
- Define the following :
  - Poisson's ratio,
  - Volumetric strain, and
  - Bulk modulus
- Derive an expression for the impact stress induced due to a falling load.
- Write short notes on :
  - Resilience
  - Proof resilience, and
  - Modulus of resilience

### OBJECTIVE TYPE QUESTIONS

- Hooke's law holds good upto
  - yield point
  - elastic limit
  - plastic limit
  - breaking point
- The ratio of linear stress to linear strain is called
  - Modulus of elasticity
  - Modulus of rigidity
  - Bulk modulus
  - Poisson's ratio



3. The modulus of elasticity for mild steel is approximately equal to
  - (a) 80 kN/mm<sup>2</sup>
  - (b) 100 kN/mm<sup>2</sup>
  - (c) 110 kN/mm<sup>2</sup>
  - (d) 210 kN/mm<sup>2</sup>
4. When the material is loaded within elastic limit, then the stress is ..... to strain.
  - (a) equal
  - (b) directly proportional
  - (c) inversely proportional
5. When a hole of diameter 'd' is punched in a metal of thickness 't', then the force required to punch a hole is equal to
  - (a)  $d.t.\tau_u$
  - (b)  $\pi d.t.\tau_u$
  - (c)  $\frac{\pi}{4} \times d^2 \tau_u$
  - (d)  $\frac{\pi}{4} \times d^2.t.\tau_u$

where  $\tau_u$  = Ultimate shear strength of the material of the plate.
6. The ratio of the ultimate stress to the design stress is known as
  - (a) elastic limit
  - (b) strain
  - (c) factor of safety
  - (d) bulk modulus
7. The factor of safety for steel and for steady load is
  - (a) 2
  - (b) 4
  - (c) 6
  - (d) 8
8. An aluminium member is designed based on
  - (a) yield stress
  - (b) elastic limit stress
  - (c) proof stress
  - (d) ultimate stress
9. In a body, a thermal stress is one which arises because of the existence of
  - (a) latent heat
  - (b) temperature gradient
  - (c) total heat
  - (d) specific heat
10. A localised compressive stress at the area of contact between two members is known as
  - (a) tensile stress
  - (b) bending stress
  - (c) bearing stress
  - (d) shear stress
11. The Poisson's ratio for steel varies from
  - (a) 0.21 to 0.25
  - (b) 0.25 to 0.33
  - (c) 0.33 to 0.38
  - (d) 0.38 to 0.45
12. The stress in the bar when load is applied suddenly is ..... as compared to the stress induced due to gradually applied load.
  - (a) same
  - (b) double
  - (c) three times
  - (d) four times
13. The energy stored in a body when strained within elastic limit is known as
  - (a) resilience
  - (b) proof resilience
  - (c) strain energy
  - (d) impact energy
14. The maximum energy that can be stored in a body due to external loading upto the elastic limit is called
  - (a) resilience
  - (b) proof resilience
  - (c) strain energy
  - (d) modulus of resilience
15. The strain energy stored in a body, when suddenly loaded, is ..... the strain energy stored when same load is applied gradually.
  - (a) equal to
  - (b) one-half
  - (c) twice
  - (d) four times

### ANSWERS

- |         |         |         |         |         |
|---------|---------|---------|---------|---------|
| 1. (b)  | 2. (a)  | 3. (d)  | 4. (b)  | 5. (b)  |
| 6. (c)  | 7. (b)  | 8. (a)  | 9. (b)  | 10. (c) |
| 11. (b) | 12. (b) | 13. (c) | 14. (b) | 15. (d) |